

BIPARK30

2-POST PARKING LIFTS

NELCA

SYSTEMS

WWW.NELCASYSTEMS.CA



REDEFINING SPACE WHERE IT MATTERS.

WHAT IS THE BIPARK30?

NELCA
SYSTEMS

OMER BiPark 30 is a **premium two-post parking lift** engineered and **manufactured in Italy** for car storage in both **residential and commercial** settings. This compact, above-ground stacker doubles your parking capacity in a remarkably small footprint — all without excavation or major construction.

What truly sets the **BiPark 30** apart is the **engineering pedigree** behind it. Manufactured by O.M.E.R. S.p.A. — a world leader in vehicle lift manufacturing with over 45 years of experience — every unit is built to a higher standard. The **galvanized platform** design channels fluids away from the vehicle below, the **unique torsion bar** keeps the **platform perfectly parallel** at all times, and the electrically-actuated mechanical locking device guarantees a **safe locking position at 1-inch intervals**.

Add hot-dipped galvanization, a waterproof IP54 push-button board, and a waterproof control unit cover, and you have a lift purpose-built to perform reliably in outdoor conditions for decades to come..



MADE IN ITALY
CSA CERTIFIED



SPECIFICATIONS.

Safety is built into every detail.

Uniquely **balanced** and **reinforced**, it allows vehicles to be parked facing either direction with **no requirement for even weight distribution** — giving operators the flexibility to run their facility the way they see fit.

BIPARK30. TECHNICAL SPECIFICATIONS

PLATFORM DIMENSIONS	2.2M WIDE - 3.51METERS LONG
LIFTING CAPACITY PER PLATFORM	UP TO 6,600 LBS
TRAVEL DISTANCE	UP TO 21 METER
CONFIGURATION	2-POST
STRUCTURE MATERIAL	POWDER COATED
COLUMNS HEIGHT	3.340 METERS / 10' - 11.5"
TOTAL WIDTH	2.602M / 8' - 6.4"
POWER	220V - SINGLE PHASE
COLOR	STANDARD LIGHT GRAY - CUSTOMIZATION AVAILABLE
CERTIFICATIONS	CSA

SPECIFICATIONS.

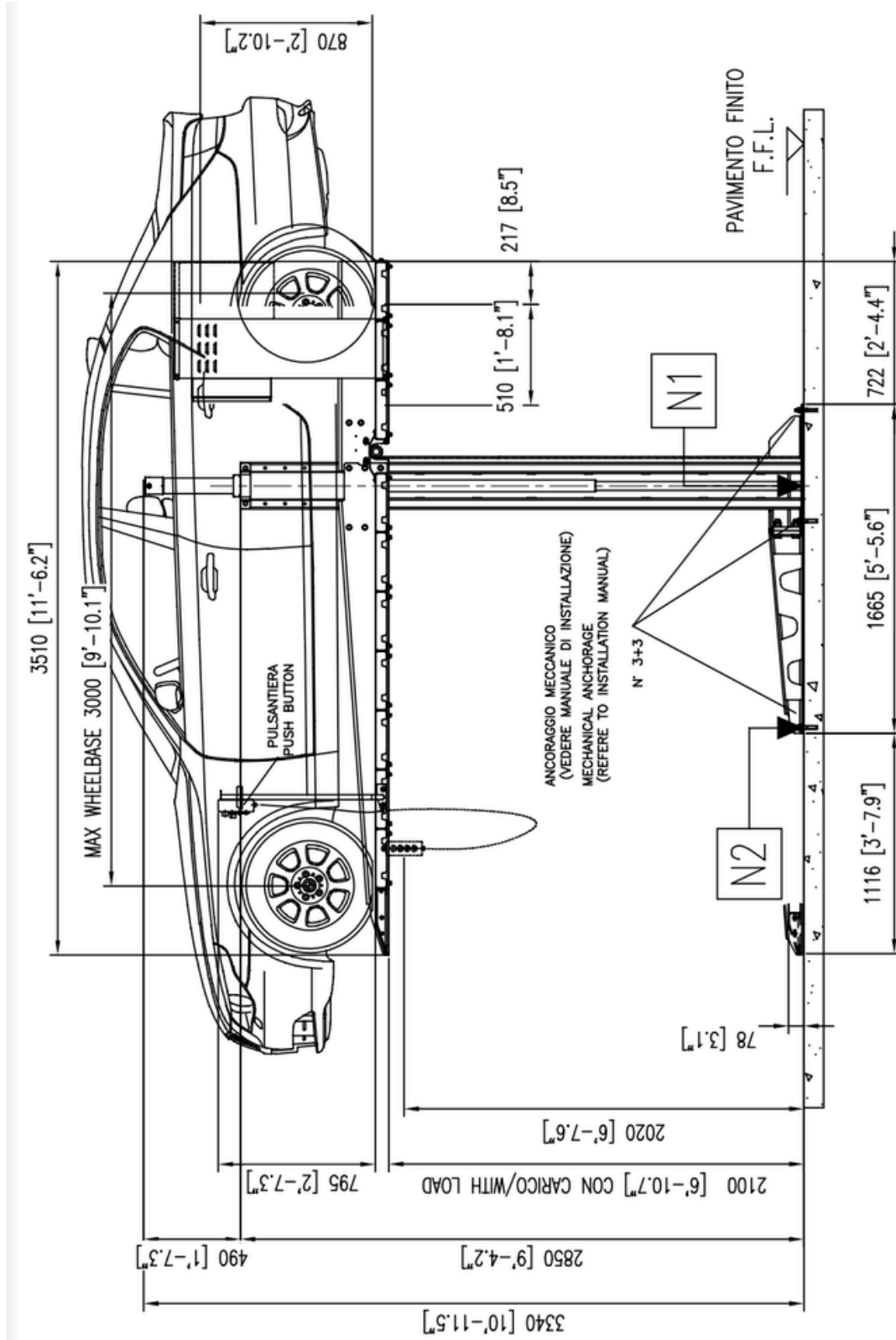

SPECIFICATIONS.

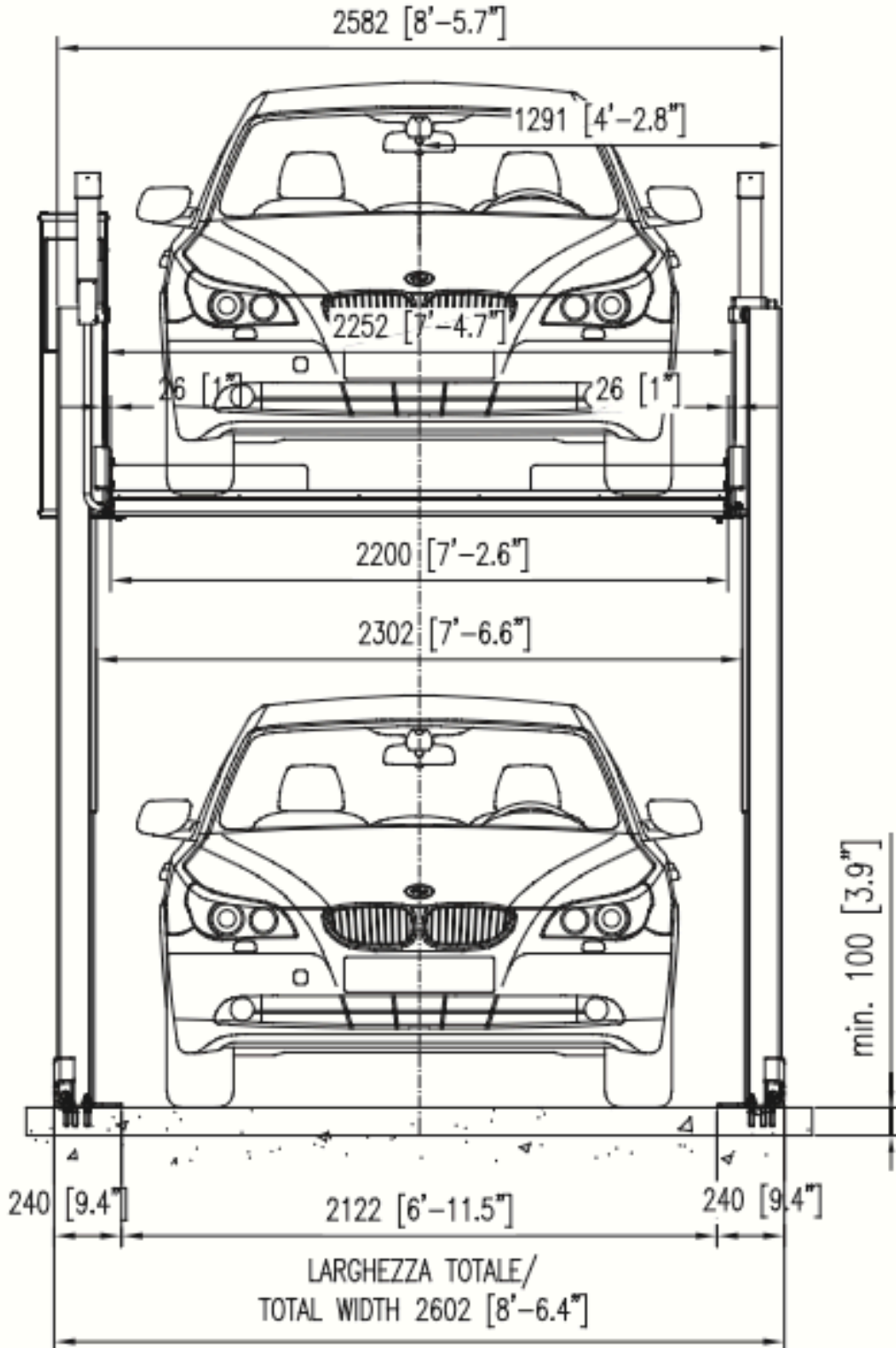

LET'S TAKE A CLOSER LOOK.

Engineered for Efficiency and Longevity.

Smooth-rolling wheels and **reinforced nylon guides** minimize friction between the column and carriage, reducing energy consumption and mechanical wear. Channeled, **hot-dip galvanized platform** drains water away from the vehicle below — protecting against rust and ensuring decades of reliable performance.

Contact Nelca Systems today for your free consultation and quote.

Let's breakdown the components

Hydraulic power rack
and control box

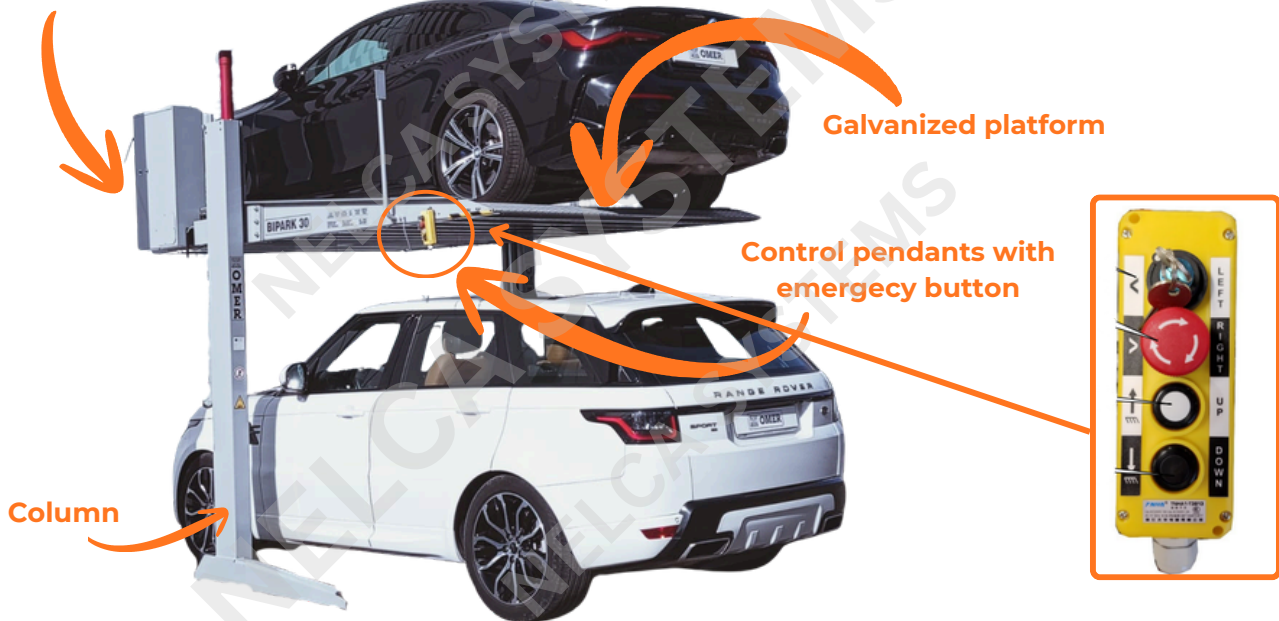

STANDARD FEATURES

- CSA Power Rack
- CSA control box
- 1 Control pendants - UP/DOWN Buttons and Emergency Stop + key switch
- torsion bar

OPTIONAL FEATURES

- Hot dipped galvanization for outside use
- Non standard power supply like 460/3/60 Hz
- Vehicle detecting photocell for electronic collision prevention
- ICEV (Internal Combustion Engine Vehicle) battery charger
- Solar panel for ICEV battery charger

PHOTO GALLERY

NELCA
SYSTEMS



BIPARK30

2-POST PARKING LIFTS



NELCA

SYSTEMS

WWW.NELCASYSTEMS.CA

 www.nelcasystems.ca

 +1 (437) 326-3102

 contact@nelcasystems.com

 Toronto, Canada